

optibelt **STD**®

The Optibelt STD® timing belts have semi-circular teeth for special shear-strength. The timing belt tooth geometry combined with the belt structure leads to even load distribution and optimized engagement of the toothed pulleys.

Characteristics

- Optimized timing belt section
- Defined support of the tooth in the gap
- Smooth engagement of the teeth into the pulley gap
- Low noise level
- Small clearance of the tooth gaps
- High performance capability

Advantages

- Interchangeability of the belt for existing pulleys
- Universal fields of application
- Ability to run in existing pulleys without loss of performance
- High functional reliability
- Maintenance-free
- Withstands temperatures from -30 °C to 100 °C
- Degree of efficiency up to 98 %

Examples of use:

- | | |
|-----------------------|--|
| Office machines | ■ Photocopiers, printers, fax machines, document shredders |
| Home appliances | ■ Kitchen machines |
| Gardening tools | ■ Lawn mowers |
| Manual equipment | ■ Manual planer, pulp grinder |
| Vehicles | ■ Window lifters, seat adjustments |
| Industrial facilities | ■ Textile machines |
| | ■ Printing units |
| | ■ Machine tools |
| | ■ Pumps, compressors |
| | ■ Centrifuges |



STD®

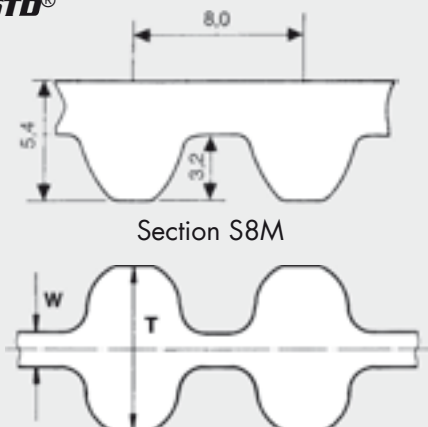

Optibelt STD® also available in HP or HL design

Sections:

S3M; S5M; S8M; S14M; DS8M

Dimensions:

120 to 5012 mm

Toothed pulleys:

Optibelt STD® timing belts run in standard STD® pulleys. Special pulleys are not required.